

ATAC

Active Tuning Amplitude Controller

by

TS ENGINEERING, INC.

Version 6.5

Manual

TS ENGINEERING, INC.

240 High Street

Washingtonville, Ohio 44490

(800) 957-4390

(330) 427-0125

www.tsengineering.com

email: tsenginc@aol.com

Table of Contents

Introduction	3
ATAC Controller	4
External Controls and Connections	5
Motion Sensor	7
Operation Setup	8
Modes of Operation	9
Internal Adjustments	10
Adjustments for proper operation	11
Frequency Sweep Power Level	11
Full Scale Intensity Adjust	12
Loop Gain	12
Universal Input OPERATE / HOLD Enable	13
Display Select	13
Soft Start	13
Frequency Control Adjustment	14
Factory DIP switch preset values	14
ATAC Specifications	14
ATAC Main Board Wiring Diagram	15
Motion Sensor / DIN Connector Wiring Diagram	16
LCD Display (Optional) Wiring Diagram	16

Introduction

The **ATAC** feeder control is a flexible, all digital controller designed to maximize the performance of vibratory feeders. In its standard mode of operation the **ATAC** controller maintains a feeders vibration intensity at a preset value specified by the user (Amplitude Control). In addition to controlling the vibration intensity, the controller will continually search for the natural frequency of the feeder and excite the feeder at that frequency (Active Tuning). Together, Active Tuning and Amplitude Control of the **ATAC** yield:

- Consistent feeder performance over a wide range of loading conditions.
- Freedom to build and operate a feeder with any natural frequency from 40 Hz to 160 Hz.
- Feeders can operate from 50 Hz (Europe) or 60 Hz (North America) supply power without modifying the feeder springs or mass.
- Minimum coil current
- Minimum coil heating
- Minimum supply current
- Minimum power consumption
- Power factor correction
- Fault tolerance (Feeders with broken springs can still operate, eliminating the need for unscheduled maintenance)
- Many more feeders can be placed on the same electrical circuit without circuit overload.

The **ATAC** Controller is a true closed loop control system. There are two components to the **ATAC** Control System, the Motion Sensor and the **ATAC** controller.

ATAC Controller

The **ATAC** Controller is the primary unit. It automatically controls the supply of power to the feeder bowl. It will drive the bowl at the bowl's natural frequency and adjust the output voltage to keep the vibration intensity at a level specified by the user via the Set Point Control knob.

The **ATAC** Controller is depicted in figure 1.

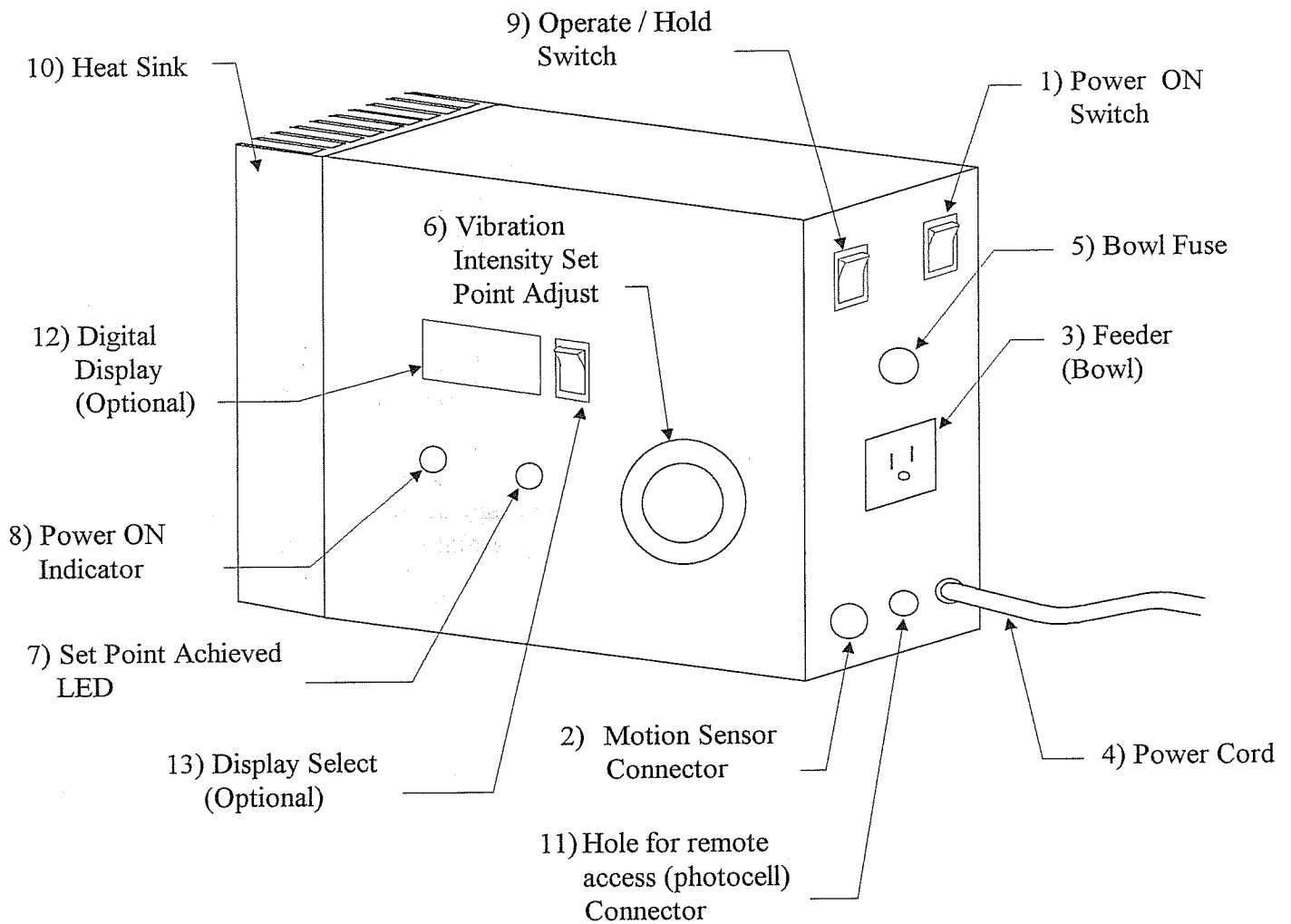

Figure 1. **ATAC** Active Tuning Amplitude Controller

External Controls and Connections

1. **Power ON switch** - This switches the unit on and off. Upon power up there is a 3 second delay for internal calibration. In the standard mode of operation (Mode 1) this is followed by a 160 to 40 Hz frequency sweep. This is to find the approximate natural frequency of the bowl and takes about 20 seconds. The unit then goes into normal operation. **ALWAYS TURN POWER OFF BEFORE CONNECTING OR DISCONNECTING FEEDER BOWL OR SERVICING BOWL FUSE.**
2. **Motion Sensor Connector** - This is a female 5 pin DIN connector for attaching the motion sensor to the controller. The motion sensor must be mounted on the bowl with its axis of sensitivity parallel to the motion of the bowl. The optimum place to mount the motion sensor is at or near the perimeter of the bowl. (For linear feeders, mount the motion sensor with its axis of sensitivity parallel to the motion of the feeder.)
3. **Feeder Bowl Power Outlet** - This is where the feeder bowl magnet coils are plugged in to get power. This is the variable frequency variable power output power source. **ONLY A FEEDERS MAGNET COILS SHOULD BE PLUGGED INTO THIS OUTLET.**
4. **Power Cord** - This cord plugs into a standard 120 Volt AC outlet to power the controller. The controller requires 95 - 140 Volts AC at 45 - 65 Hz. For the 220 volt version of the **ATAC**, 190 - 250 Volts AC is required. Input voltages greater than the maximum ratings (140 Volts and 250 Volts for the 110 volt and 220 volt versions respectively) may damage the **ATAC** Controller. If you are unsure whether you have a 110 or 220 volt **ATAC**, Open the unit and check the main board. The 110 volt version will have two vertical jumpers while the 220 volt version will have 1 horizontal jumper. Refer to figure 3 on page 10 for the location of these jumpers. No plug is supplied at the end of the power cord for the 220 volt version.
5. **Bowl Fuse** - This is a fuse in line with the feeders power outlet. It provides protection to the feeder coils in the event that there is a problem in the controller. A fuse should be used in accordance with the current rating of the feeder coils. The controller is rated at 12 Amps RMS maximum, so do not use a fuse rated higher than 12 Amps (7 Amps is the maximum for the 220 volt version). A ceramic fuse is recommend.

6. **Vibration Intensity Set Point Adjust** - This tell the controller what vibration intensity is desired. It is NOT a direct output power control knob (except in Mode 4). The controller will adjust the output power (and frequency) so as to make the vibration intensity of the bowl meet the value specified by the vibration intensity set point adjust.
7. **Set Point Achieved LED** - This Light Emitting Diode lights when the feeder bowl vibration intensity is very close to the desired set point (within 3% of full scale intensity). If for some reason the motion sensor is disconnected from the controller, the controller will stop the bowl operation and this LED will blink, indicating the fault. This LED will illuminate for three seconds upon power up.
8. **Power On Indicator LED** - This Light Emitting Diode lights when the unit is powered.
9. **Operate / Hold Switch** - This allows the operator to stop the bowl motion, then restart it again without going through the power up sequence. This is wired in parallel with the contact closure sensing for stopping the bowl via a photo cell, PLC, etc.
10. **Heat Sink** - This heat sink dissipates the heat generated by the electronics. It is specified for a continuous 12 Amp RMS feeder current (7 Amp RMS for the 220 volt version) in an ambient temperature environment of 115⁰ F. Do not block air flow around heat sink. CAUTION: AT HIGH VALUES OF CONTINUOUS LOAD CURRENT, THE HEAT SINK CAN BE HOT TO THE TOUCH!
11. **Hole for remote access** - This hole comes covered. Its purpose is to allow the photocell wires access inside the box. This version of the ATAC comes with a wire and strain relief to be mounted through this hole if use with a photocell is desired.
12. **Digital Display** - The optional display will display the current operation frequency, or the speed of the feeder motion.
13. **Display Select** - This switch changes what is being displayed. Frequency is displayed in cycles per second (Hz). Vibration Intensity is displayed as average feeder speed in feet per minute.

Motion Sensor

The motion sensor tells the **ATAC** controller how the feeder is performing. The sensor must be mounted so that the axis of sensitivity is aligned with the motion of the feeder. That is, the sensor must vibrate along its Axis of Sensitivity. This is depicted in figure 2. For a bowl feeder, the sensor should be mounted near the perimeter of the bowl with the direction of the mounting screws (axis of sensitivity) pointing in the direction of parts flow.

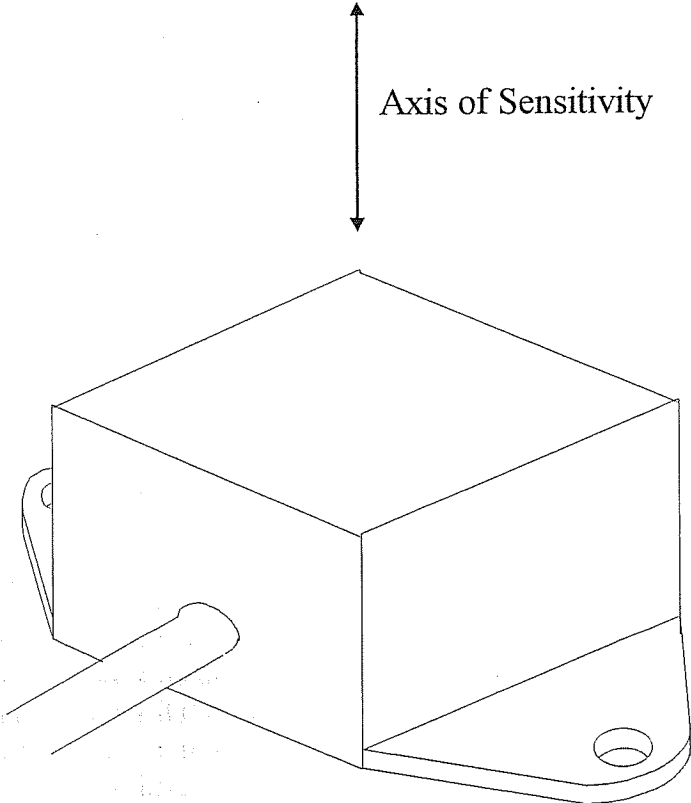

Figure 2. Motion Sensor Axis of Sensitivity

At the other end of the motion sensor is a 5 pin male DIN connector. This fits into the 5 pin female DIN connector located on the lower right side of the **ATAC** controller.

Operation Setup

The **ATAC** controller is designed and factory preset to require as little adjustments as possible. On most feeders, only the following setup procedure should be required.

1. Mount the motion sensor near the bowls perimeter with the proper orientation (figure 2).
2. Plug the motion sensor into the **ATAC** controller via the 5 pin DIN connector located on the right side of the **ATAC** controller.
3. Plug the feeder bowl power cord into the power outlet on the right side of the **ATAC** controller. At this time you may wish to replace the bowl fuse (12 Amps factory value) with one which is specific to the drive coils current rating. (Do not use a fuse rated over 12 Amps.)
4. Plug the **ATAC** controller into a standard outlet (95-140 volts RMS AC 45-65 Hz). Caution: Use of input power at a higher voltage rating (>140 volt RMS) may damage the **ATAC** controller. If you have the 220 Volt version of the **ATAC**, the input voltage must be between 190-250 volts RMS AC 45-65 Hz. The input voltage must not exceed 250 volts or damage to the **ATAC** may result. If you are unsure as to which model (110 volt or 220 volt) you have, check the jumper arrangement located below the fuse on the main board. (see figure 3 page 10) Two jumpers correspond to the 110 volt version. One jumper corresponds to the 220 volt version.
5. Insure that the Operate / Hold Switch located on the right side of the **ATAC** controller is in the Operate position.
6. Turn on the **ATAC** controller via the Power switch located on the right side of the **ATAC** controller.
7. In the standard mode of operation, upon turning the unit on there is a 3 second delay followed by a 160 to 40 Hz frequency sweep. Upon completion of the frequency sweep, the controller will begin normal operation at the bowls natural frequency. The frequency sweep will take about 25 seconds to complete. At this point, simply adjust the Vibration Intensity Set Point knob to achieve the desired vibration intensity. The Set Point Achieved LED will tell you when the bowls vibration intensity is at the set point. The **ATAC** controller will maintain this vibration intensity level regardless of bowl loading, line voltage variation, etc.

This applies to the Standard Mode of operation or Mode 1. The **ATAC** come factory preset for this mode of operation. Other modes of operation are available.

Modes of Operation

The **ATAC** controller can operate in one of four modes of operation. Which mode the **ATAC** is in is selected by DIP switches 2 & 3. These four modes are as follows:

- Mode 1. **Frequency Sweep Active Tuning Amplitude Control** - This is the standard mode of operation and the **ATAC** comes factory preset for this mode. In this mode of operation, the **ATAC** will perform a frequency sweep upon power up. This sweep will begin at 160 Hz and end at 40 Hz. The frequency sweep will take about 20 seconds. Upon completion of the frequency sweep, the **ATAC** will go into *normal operation* at the frequency which resulted in the maximum feeder motion (the feeders natural frequency). The output voltage used during the sweep is determined by DIP switches 6 & 7. During normal operation, the **ATAC** will automatically adjust the output voltage to maintain the vibration intensity at the desired set point (*Amplitude Control*). The **ATAC** will also continuously adjust the drive frequency for maximum efficiency (*Active Tuning*).
- Switch 2 = OFF
Switch 3 = OFF
- Mode 2. **Fixed Frequency Start Active Tuning Amplitude Control** - This mode of operation is similar to Mode 1 however no frequency sweep is performed. The **ATAC** will simply go into *normal operation* at the frequency specified by the frequency control adjustment (the blue adjustment pot on the main circuit board - C). The primary purpose of this mode is to avoid the 20 second frequency sweep at power up. However additional setup is required in that the startup frequency is not found automatically, it needs to be specified. The setting of this frequency adjustment is best done in Mode 4. There is still a 3 second delay at startup for the **ATAC** to perform internal calibrations.
- Switch 2 = ON
Switch 3 = OFF
- Mode 3. **Fixed Frequency Amplitude Control** - This mode of operation is similar to mode 2 however the frequency is fixed. During normal operation, *amplitude control* is performed but there are no adjustments made to the frequency. *Active Tuning* is turned off. The driving frequency is determined by the frequency control adjustment (the blue adjustment pot on the main circuit board - C) at power up. The frequency control adjustment is read once at power up, and the **ATAC** drive frequency forever remains at that frequency. The setting of the frequency adjustment is best done in Mode 4.
- Switch 2 = OFF
Switch 3 = ON
- Mode 4. **Fixed Frequency Open Loop Control** - This mode operation is similar to mode 3, however in this case the *amplitude control* is also turned off. The output voltage is determined by the front panel set point knob, and the frequency is determined by the frequency control adjustment (the blue adjustment pot on the main circuit board - C). This mode of operation is primarily intended for making frequency adjustments to be used in modes 2 or 3 since frequency adjustments can be quite difficult to make while the *amplitude control* is active.
- Switch 2 = ON
Switch 3 = ON

If feeder performance does not meet with satisfaction, internal adjustments may be required. These adjustments depend on the mode of operation and are described in the next sections.

Internal Adjustments

To insure operator safety, internal adjustments should be made with the **ATAC** controller turned off, and unplugged.

There are 7 DIP switches and 3 trimpots labeled A, B, and C (yellow, red and blue respectively).

The fuse on the main board is the input fuse. Should this fuse blow, it should be replaced with a 0.25" x 1.25" Slo-Blow fuse rated at 6 Amps. (Two fuses at 4 Amps for the 220 volt version)

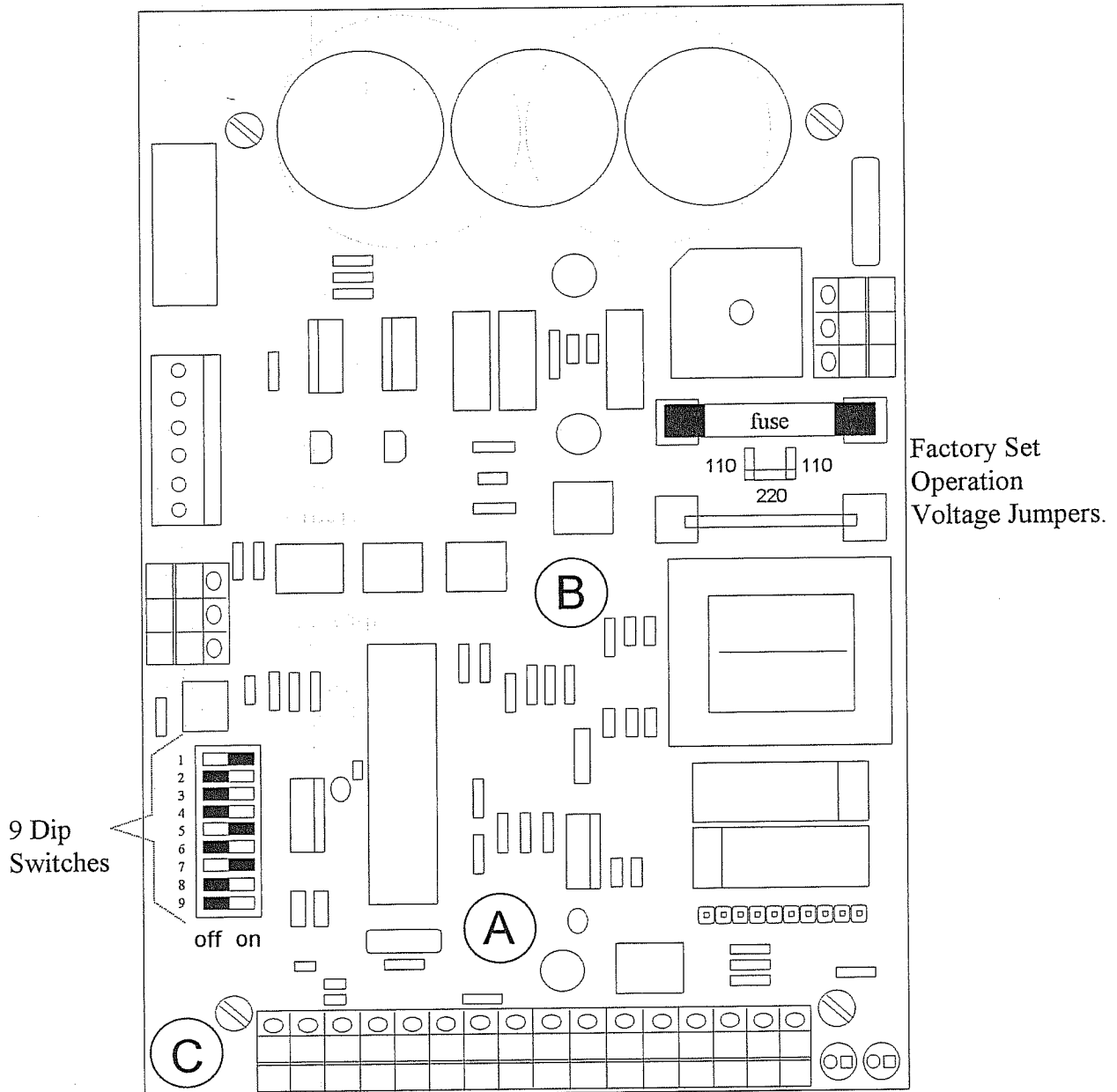

Figure 3. Simplified diagram of the main circuit board showing location of the main input fuse, the 9 Dip Switches, and the three trimpots labeled A, B & C.

Adjustments for proper operation

There are several adjustments which may be needed for proper operation.

Frequency Sweep Power Level

This adjustment only applies when the **ATAC** is setup to run in Mode 1. This is the frequency sweep power level. The initial frequency sweep is performed so the **ATAC** controller can automatically find the natural frequency of the feeder. However, at the natural frequency the feeder may vibrate excessively. In this event you will want to decrease the frequency sweep power level. If the feeder is heavily loaded upon power up, then the vibration intensity at the natural frequency may be too small, and the controller may not “find” the feeders natural frequency. In this event, you will want to increase the frequency sweep power level. It may be necessary to adjust the frequency sweep power level to accommodate these two extremes. The factor preset value will probably work well on most feeders.

To adjust the frequency sweep power level, there are 4 power level settings. They are:

1. Low
2. Medium - Low
3. Medium - High
4. High

Which level is used is determined by DIP switches 7 and 6 as follows:

Switch 6 = ON Low
Switch 7 = ON

Switch 6 = OFF Medium - Low (factory preset)
Switch 7 = ON

Switch 6 = ON Medium - High
Switch 7 = OFF

Switch 6 = OFF High
Switch 7 = OFF

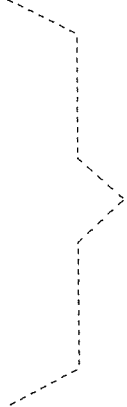

ONLY
VALID
IN
MODE 1

Full Scale Intensity Adjust

This adjustment is made via trimpot A (yellow). This adjustment alters the gain on the motion sensor, and thus changes the Full Scale vibration Intensity. Rotating this pot fully clockwise causes maximum motion sensor gain, and thus minimum full scale vibration intensity. Fully counter clockwise rotation cause minimum vibration sensor gain, and thus maximum full scale vibration intensity. There is a factor of 4 between fully CCW and fully CW rotation.

Note: Trimpot B (red) is factory preset, and should not be adjusted.

Loop Gain

This adjustment results in a tradeoff between speed of response (to a step change of the set point, or sudden bowl loading) and control stability. There are four loop gains values to choose from, and are selected by DIP switches 5 and 4 as follows:

Switch 4 = ON Full Loop Gain. This results in the fastest response, but
Switch 5 = ON result in unstable amplitude control for some feeders.

Switch 4 = OFF Full Loop Gain / 2. (factory preset)
Switch 5 = ON

Switch 4 = ON Full Loop Gain / 4.
Switch 5 = OFF

Switch 4 = OFF Full Loop Gain / 8. Most stable, but is the slowest.
Switch 5 = OFF

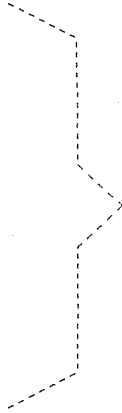

ONLY
VALID
IN
MODES
1,2 and 3

A High Q bowl or feeder may be difficult to control with large loop gain. In this case select a lower loop gain.

Universal Input Hold / Operate Enable

This enables the universal input to place the control in OPERATE mode. Any voltage, AC or DC, from 15 volts RMS minimum, to 120 Volts RMS maximum applied to pins 1 and 3 of J6 will put the unit in OPERATE mode. A zero volt input applied to pins 1 and 3 of J6 will put the unit into HOLD mode. The contact closure input (J3) will still function, normally. The input impedance is very high for connection to a photocell.

Switch 1 = ON Universal Input disabled (factory preset).

Switch 1 = OFF Universal Input enabled.

Display Select

Only valid for models with LCD Display, this switch selects what is to be displayed; Frequency or Speed. It is redundant to the front panel switch in AT-X050 models, and should be left off for these models. For OEM kit versions with LCD Displays, this switch eliminates the need for a panel switch for selecting Frequency or Speed. In this configuration, the Display signal wire should be connected to position 3 of J4.

Switch 8 = ON Frequency display override

Switch 8= OFF Speed display (factory preset)

Soft Start

Many vibratory feeders will “surge” upon restart (going from hold to operate). This won't happen if the feeder is excited at its natural frequency, as in modes 1 & 2, but can occur in mode 3 where the feeder can be excited at a frequency different from its natural frequency. The soft start eliminates this surging by slowly increasing the power over one second to its running value.

Switch 9 = ON Soft Start Enabled

Switch 9= OFF Soft Start Disabled (factory preset)

Frequency Control Adjustment

In modes 2,3 and 4, the drive frequency is initially determined via trimpot - C (Blue). It is located at the lower left of the **ATAC** Main board. This adjusts the drive frequency from 40 Hz to 160 Hz (fully CW) in ½ Hz increments. This adjustment is read only at power up in modes 2 and 3, and is read continuously in mode 4. If at power up this adjustment is fully counter clockwise, then the frequency is determined by DIP switches 6 & 7 accordingly:

Switch 6 = ON 50.0 Hz
Switch 7 = ON

Switch 6 = OFF 60.0 Hz
Switch 7 = ON

Switch 6 = ON 100.0 Hz
Switch 7 = OFF

Switch 6 = OFF 120.0 Hz
Switch 7 = OFF

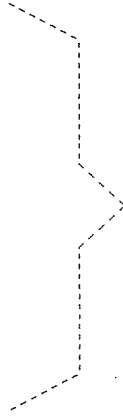

**ONLY
VALID
IN
MODES
2,3 and 4**

These are perhaps the most common vibratory feeder frequencies. However, when using these frequencies, the drive frequency to the feeder is still independent of the input frequency from the power source.

Factory DIP switch preset values

- Switch 1 = ON
- Switch 2 = OFF
- Switch 3 = OFF
- Switch 4 = OFF
- Switch 5 = ON
- Switch 6 = OFF
- Switch 7 = ON
- Switch 8 = OFF
- Switch 9 = OFF

ATAC Specifications:

	110 Volt ATAC		220 Volt ATAC	
	Input	Output	Input	Output
Voltage	95-140 VAC	0-125 VAC	190-250 VAC	0-250 VAC
Current	6 Amps RMS	12 Amps RMS	4 Amps RMS	7 Amps RMS
Frequency	45-65 Hz	40-160 Hz	45-65 Hz	40-160 Hz

ATAC Main Board Wiring Diagram

7 Connectors, J1 through J7 Increasing Clockwise

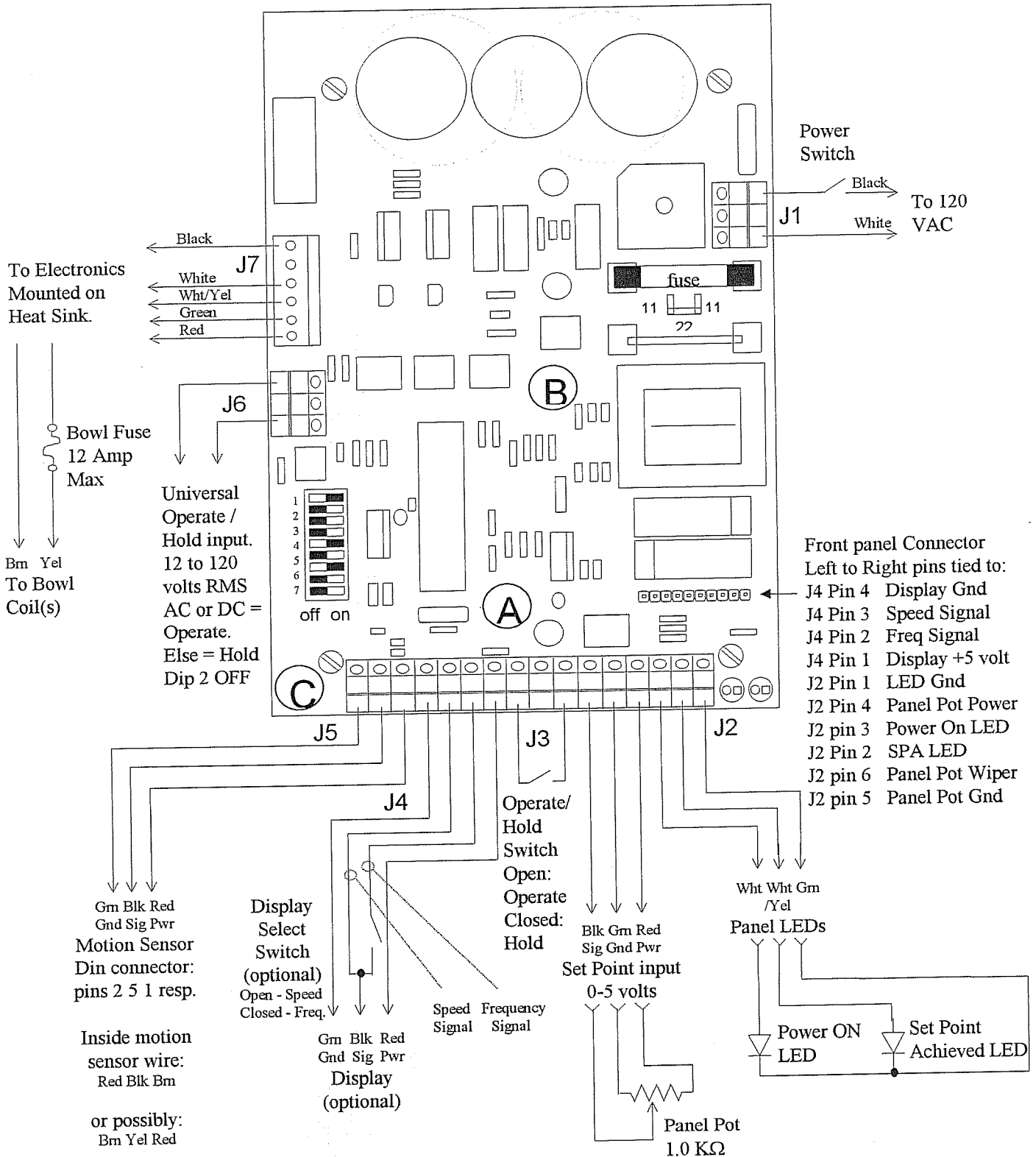

Motion Sensor DIN Connector Wiring Diagram:

• Pinout on DIN to J5 on Main Board

1 +	1
2 -	3
3 NC	NC
4 NC	NC
5 Signal	2
Shell Shield	

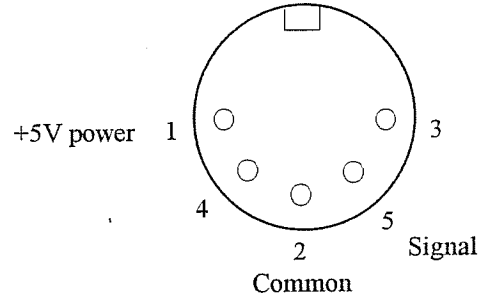

Contact Pins: Looking into motion sensor connector.
The shell is tied to the shield

LCD Display (Optional) Wiring Diagram:

For a single display to display both speed and frequency (switched):

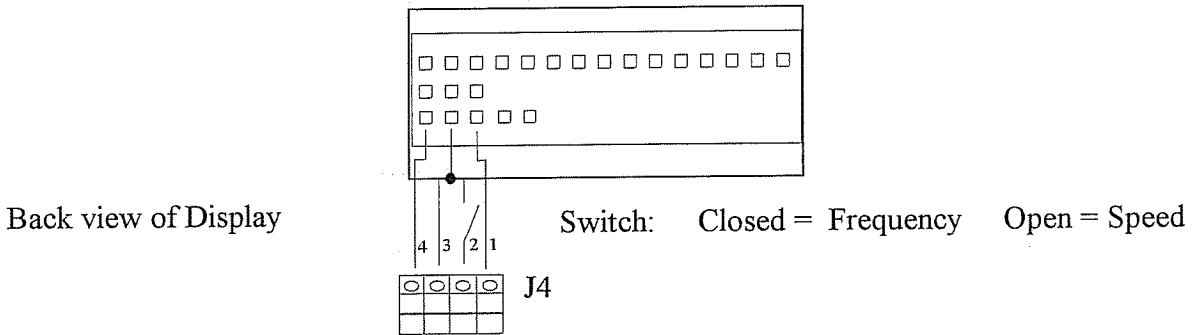

For a two separate displays, one each for speed and frequency:

