

4/4/07

ATAC

Active Tuning Amplitude Controller

by

TS ENGINEERING, INC.

Version 7.9.1

and

Version 7.9.2

Operations Manual

TS ENGINEERING, INC.

240 High Street

Washingtonville, Ohio 44490

(800) 957-4390

(330) 427-0125

www.tsengineering.com

email: info@tsengineering.com

Lifetime Warranty

TS Engineering, Inc. warrants that the equipment manufactured and sold by it will, upon shipment, be free of defects in workmanship or material. Should any failure to conform to this warranty become apparent after the date of shipment, TS Engineering, Inc. shall, upon prompt written notice from the purchaser, correct such nonconformity by repair or replacement, F.O.B. factory of the defective part or parts. Correction in the manner provided above shall constitute a fulfillment of all liabilities of TS Engineering, Inc. with respect to the quality of the equipment.

THE FOREGOING WARRANTY IS EXCLUSIVE AND IN LIEU OF ALL OTHER WARRANTIES OF QUALITY WHETHER WRITTEN, ORAL, OR IMPLIED (INCLUDING ANY WARRANTY OF MERCHANTABILITY OF FITNESS FOR PURPOSE). TS ENGINEERING, INC. SHALL NOT BE LIABLE FOR ANY INCIDENTAL OR CONSEQUENTIAL DAMAGES OF ANY KIND RESULTING FROM THE USE OF THIS UNIT.

TS Engineering, Inc. shall not be responsible for and the purchaser shall have no right to consequential damages resulting from the use of the unit due to causes beyond the control and without the fault or negligence of TS Engineering, Inc. including but not limited to acts of God, fire, negligent acts, civil unrest, power failures, power surges, flood, accident, actions of third parties, failure to follow proper installation, operation, or maintenance, unauthorized repairs, alterations, abused, misused, misapplication or improper environment.

The remedy (ies) provided above shall be purchaser's sole remedy (ies) for any failure of TS Engineering, Inc. to comply with the warranty provisions, whether claims by the purchaser are based in contract or in tort (including negligence).

Furthermore, TS Engineering, Inc. does not warrant equipment against normal deterioration due to environment. Factors such as corrosive gases, liquids and solid particulates can be detrimental and can create the need for repair or replacement as part of normal wear and tear during the warranty period.

Notations in this Manual

This manual uses two symbols to draw attention to or denote actions, which should be performed cautiously, or avoided altogether.

 Means TAKE NOTE of this statement, or BE CAUTIOUS when performing this action.

 Means DO NOT DO THIS, or DO NOT ALLOW THIS TO HAPPEN.

Table of Contents

Warranty	2
Notations in this Manual	2
Introduction	5
Notations in this manual	5
The ATAC Controller (<i>Figure 1</i>)	6
External Controls and Connections.	7
Motion Sensor (<i>Figure 2 & Figure 3</i>)	9
Operation Setup	10
The ATAC Circuit Board 7.9.1 (<i>Figure 4</i>)	11
The ATAC Circuit Board 7.9.2 (<i>Figure 5</i>)	12
DIP Switch Settings	13
Factory Preset DIP Switch Settings	14
Modes of Operation	15
Mode 1.	15
Mode 2.	15
Mode 3.	17
Mode 4. (Obsolete).....	18
Operating the Atac.	20
Frequency Sweep Power Level	20
Full Scale Intensity Adjust (<i>Figure 7</i>).....	20
Loop Gain	21
Universal Input Enable for Operate / Hold (<i>Figure 6</i>).....	21

Table of Contents

Operate / Hold Relay Output.....	22
Display Select.....	22
Soft Start.	22
Master / Slave Interconnection.....	23
Wiring Diagrams.	24
Motion Sensor DIN Connector Wiring Diagram	24
Motion Sensor CE Connector Wiring Diagram	24
LCD Display (Optional) Wiring Diagram	25
Atac Specifications.....	26
Recommended Replacement Fuse Values.....	26
Appendix A.....	27
Atac Controller 110V Schematics.....	27
Atac High Voltage Section Ver. 7.9.1 (<i>Figure 8</i>).....	28
Atac Micro Controller Section Ver. 7.9.1 (<i>Figure 9</i>)	29
Atac Low Voltage Power Supply Section Ver. 7.9.1 (<i>Figure 10</i>).....	30
Appendix B.....	31
Atac Controller 110V CE Schematics.....	31
Atac High Voltage Section Ver. 7.9.2 (<i>Figure 11</i>)	32
Atac Micro Controller Section Ver. 7.9.2 (<i>Figure 12</i>).....	33
Atac Low Voltage Power Supply Section Ver. 7.9.2 (<i>Figure 13</i>).....	34

Introduction

The **ATAC**, Active Tuning Amplitude Controller, is a flexible, all digital controller designed to maximize the performance of vibratory feeders. In its standard mode of operation the **ATAC** controller will maintain a feeder's vibration intensity at any value specified by the user (Amplitude Control). In addition, the controller will continually search for the natural frequency of the feeder (resonance) and excite it at that frequency (Active Tuning). Together, Active Tuning and Amplitude Control of the **ATAC** yield:

- Consistent feeder performance over a wide range of loading conditions.
- Freedom to build and operate a feeder with any natural frequency from 40 Hz to 160 Hz.
- Feeders can operate from 50 Hz (Europe) or 60 Hz (North America) supply power without modifying the feeder springs or mass.
- Minimum coil current.
- Minimum coil heating.
- Minimum supply current.
- Minimum power consumption.
- Power factor correction.
- Fault tolerance (feeders with broken springs can still operate, eliminating the need for unscheduled maintenance).
- Many feeders can be placed on the same electrical circuit without fear of circuit overload.

The **ATAC** Controller is a true closed loop control system. There are two components to the **ATAC** Control System, the Motion Sensor and the **ATAC** Controller.

Notations in this Manual

This manual uses two symbols to draw attention to or denote actions which should be performed cautiously, or avoided altogether.

! Means TAKE NOTE of this statement, or BE CAUTIOUS when performing this action.

× Means DO NOT DO THIS, or DO NOT ALLOW THIS TO HAPPEN.

The ATAC Controller

The **ATAC** Controller is the primary unit. It automatically controls the supply of power to the feeder bowl. It will drive the bowl at its *natural frequency* and adjust the output voltage to keep the vibration intensity at a level specified by the user (Set Point Adjust knob).

The **ATAC** Controller is depicted in **Figure 1**, with the numbered features described in the following section.

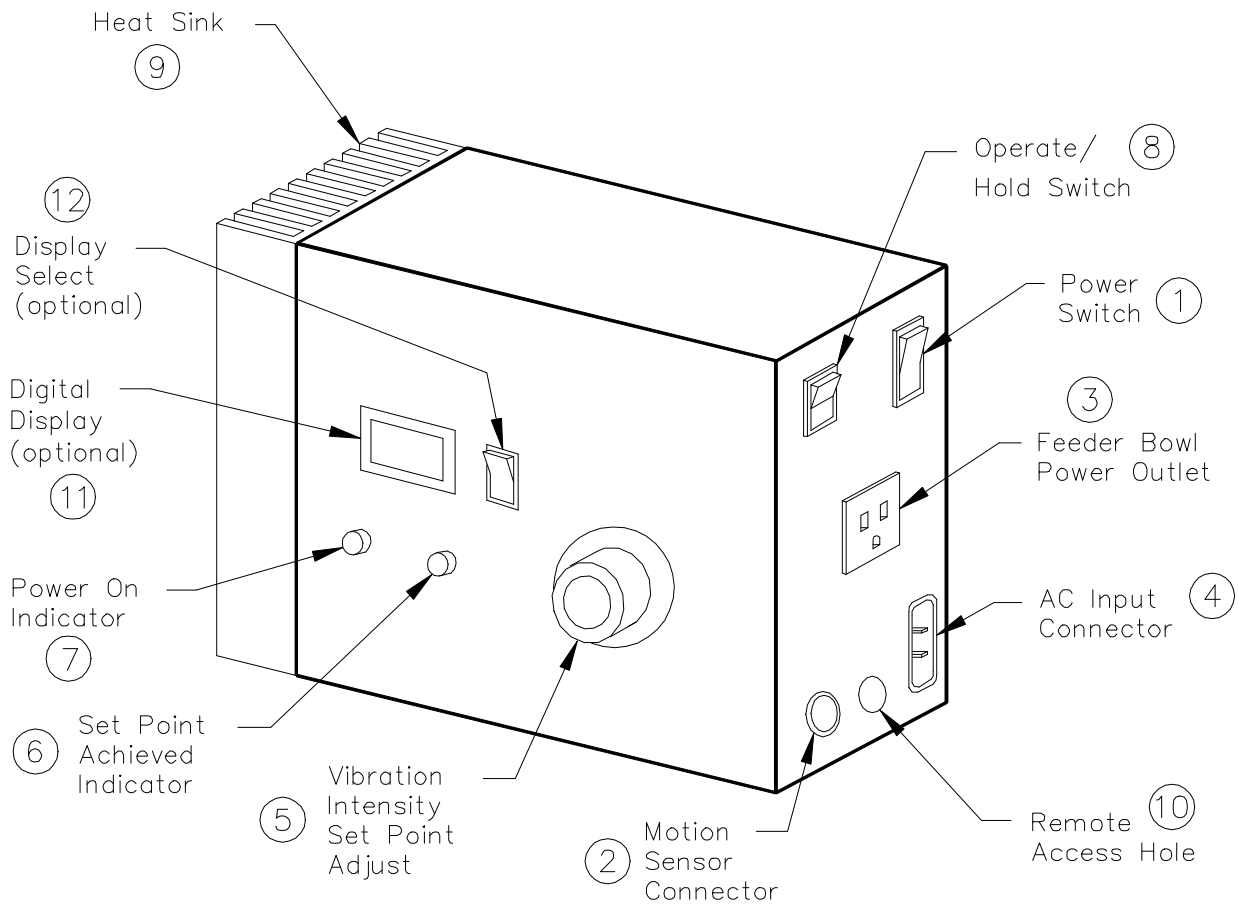

Figure 1. ATAC Active Tuning Amplitude Controller (110V model shown)

External Controls and Connections

1. **Power Switch** - In the standard mode of operation (Mode 1), powering up the unit will initiate a *frequency sweep* which begins at 160 Hz and ends at 40 Hz. This sweep is used to find the approximate *natural frequency* of the bowl and will take about 20 seconds to complete. The unit then goes into normal operation.

! ALWAYS TURN POWER OFF BEFORE CONNECTING OR DISCONNECTING A FEEDER BOWL OR SERVICING THE BOWL FUSE!

2. **Motion Sensor Connector** - This is a female 5 pin DIN connector for attaching the motion sensor to the controller. The motion sensor must be mounted on the bowl with its axis of sensitivity parallel to the motion of the bowl. The optimum place to mount the motion sensor is at or near the perimeter of the bowl (See Figures 2 and 3). For linear feeders, mount the motion sensor with its axis of sensitivity parallel to the motion of the feeder.

3. **Feeder Bowl Power Outlet** – Supplies the output to drive the feeder coils. This is a variable frequency, variable power output power source.

! ONLY A FEEDER'S MAGNET COILS SHOULD BE PLUGGED INTO THIS OUTLET!

4. **AC Input Connector** - A quick disconnect cord plugs into a standard 110 Volt AC outlet to power the controller (220 Volt AC for the 2000 and 2050 models). The 110 Volt ATAC requires 95 - 140 Volts AC @ 45 - 65 Hz. The 220 Volt model, 190 - 250 Volts AC @ 45-65 Hz is required.

✗ USE OF AN INPUT VOLTAGE HIGHER THAN THE RATED MAXIMUM (140 VOLTS RMS FOR THE 110V MODEL, 250 VOLTS RMS FOR THE 220V MODEL) CAN DAMAGE THE ATAC CONTROLLER AND VOID YOUR WARRANTY!

5. **Vibration Intensity Set Point Adjust** - Tells the controller what vibration intensity is desired. It is **NOT** a direct output power control knob (except in Mode 4). The controller will adjust the output power so as to make the vibration intensity of the bowl meet the value specified by the Vibration Intensity Set Point Adjust potentiometer.

6. **Set Point Achieved Indicator** - This LED illuminates when the feeder bowl vibration intensity is very close to the desired set point (within 3% of full scale intensity). If the motion sensor is disconnected from the controller, the controller will stop bowl operation and this LED will blink, indicating a fault. This LED will illuminate for three seconds on power up.

7. **Power On Indicator** - This LED illuminates when the unit is powered.

8. **Operate / Hold Switch** - This allows the operator to stop bowl motion, then restart it again without cycling through the power-up sweep. This is wired in parallel with the contact closure sensing for stopping the bowl via a photo cell, PLC, etc.

9. **Heat Sink** - This heat sink dissipates the heat generated by the electronics. It is specified for a continuous 15 Amp RMS feeder current in an ambient temperature environment of 40° Celsius.

! DO NOT BLOCK AIR FLOW AROUND THE HEATSINK DURING OPERATION!

10. **Remote access Hole** – The ATAC is factory delivered with this hole covered by a metal snap-in cap. In the event that any external connections are made with the circuit board, the cap may be pushed out from inside the enclosure and all wires passed through the resultant opening. This is very useful when utilizing features such as Master / Slave Interconnection, coupling of the Universal Input to a photocell or PLC output, or using the Operate / Hold relay output to communicate operational status, etc. Each unit is delivered with one strain relief bushing to use in conjunction with this pass-through. Cord Grips are available also.
11. **Digital Display (optional)** – This display will indicate either the current operating bowl frequency or the intensity of the feeder motion, *feed-rate*.
12. **Display Select (optional)** - Selects what is shown on the display. *Frequency* is read in cycles per second (Hz). *Vibration Intensity* is displayed as average feeder speed in feet per minute.

Motion Sensor

The motion sensor tells the **ATAC** controller how the feeder is performing. The sensor must be mounted so that the *axis of sensitivity* is parallel with the motion of the feeder. That is, the sensor must vibrate along its *axis of sensitivity*, **Figure 2**. For a bowl feeder, the sensor should be mounted near the perimeter of the bowl with the direction of the mounting screws (*axis of sensitivity*) pointing in the direction of parts flow.

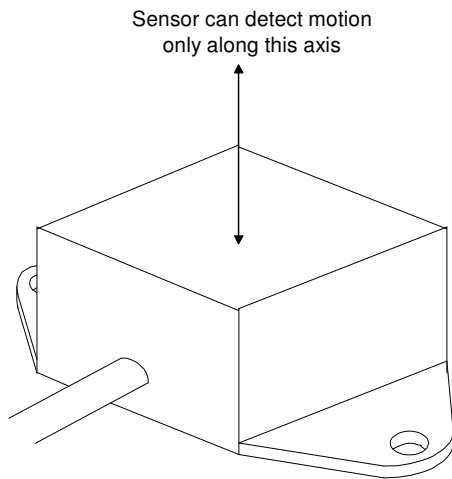

Figure 2. Motion Sensor Axis of Sensitivity

Figure 3. Illustration of proper mounting orientation on a bowl feeder utilizing a right-angle bracket secured to the bowl perimeter

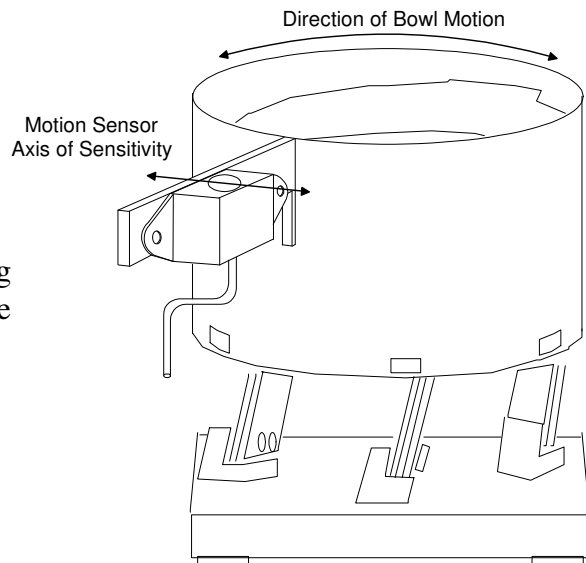

Figure 3 depicts an example of a mounting strategy for bowl feeders using a right-angle bracket mounted to the exterior of the bowl. While the use of such a bracket is not required, the Motion Sensor *must* be mounted so that its orientation with respect to bowl motion is the same as that shown in **Figure 3**, regardless of the mounting method used.

At the other end of the motion sensor cable is a 5 pin male DIN connector. This fits into the 5 pin female DIN connector located on the lower right side of the **ATAC** controller.

Operation Setup

The **ATAC** controller is designed and factory preset to require very few adjustments. On most feeders, only the following setup procedure should be required.

1. Mount the motion sensor near the bowl's perimeter with the proper orientation (*See Figures 2 and 3*).
2. Plug the motion sensor into the **ATAC** controller via the 5-pin DIN connector located on the right side of the **ATAC** controller.
3. Plug the feeder bowl power cord into the power outlet on the right side of the **ATAC** controller. At this time you may wish to replace the bowl fuse (**15 Amps factory value**) with one which is specific to the current rating of your feeder's drive coils to prevent accidental over driving. **** Do not use a fuse rated over 15 Amps ****
4. Plug the **ATAC** controller into any standard outlet, which is rated to deliver the voltage recommended for your model (95-140 Volts RMS AC @ 45-65 Hz for the 110 Volt version, 190-250 Volts RMS AC @ 45-65 Hz for the 220 Volt version).



USE OF AN INPUT VOLTAGE HIGHER THAN THE RATED MAXIMUM (140 VOLTS RMS FOR THE 110V ATAC, 250 VOLTS RMS FOR THE 220V ATAC) CAN DAMAGE THE CONTROLLER AND VOID YOUR WARRANTY!

5. Insure that the Operate / Hold Switch located on the right side of the **ATAC** controller is in the Operate position.
6. Turn on the **ATAC** controller via the Power switch located on the right side of the unit.
7. In the standard mode of operation (Mode 1), powering up the unit will initiate a **frequency sweep** which begins at 160 Hz and ends at 40 Hz. This sweep is used to find the approximate **natural frequency** of the bowl and will take about 20 seconds to complete. The unit then goes into normal operation. At this point, simply adjust the Vibration Intensity Set Point knob to achieve the desired amplitude of vibration. The Set Point Achieved LED will illuminate when the bowl's vibration intensity has reached the set point. The **ATAC** controller will then maintain this vibration level regardless of bowl loading, line voltage variations, etc.

This applies to the standard (**Mode 1**) of operation, which is the factory preset mode. Other modes of operation are available and are described in the following section. (Optional programmed micro controller may be required)

The ATAC Circuit Board 7.9.1



TO INSURE OPERATOR SAFETY, INTERNAL ADJUSTMENTS AND/OR FUSE SERVICING SHOULD ALWAYS BE DONE WITH THE ATAC CONTROLLER TURNED OFF AND UNPLUGGED!

Located on the circuit board are three trimpots labeled **POT1**, **POT 2** and **POT3**, and two fuses for the 110 volt unit and three fuses for the 220 volt unit. **POT1** is factory preset and *should never be adjusted*. **POT2** and **POT3** are user-serviceable adjustments.

If fuse replacement is required, use only 0.25" x 1.25" size fuses. The following values apply.

- (110 Volt) **F1** – 7 Amps RMS Max, **F3** – 15 Amps RMS Max
- (220 Volt) **F1 & F2** – 4 Amps RMS Max, **F3** – 7 Amps RMS Max

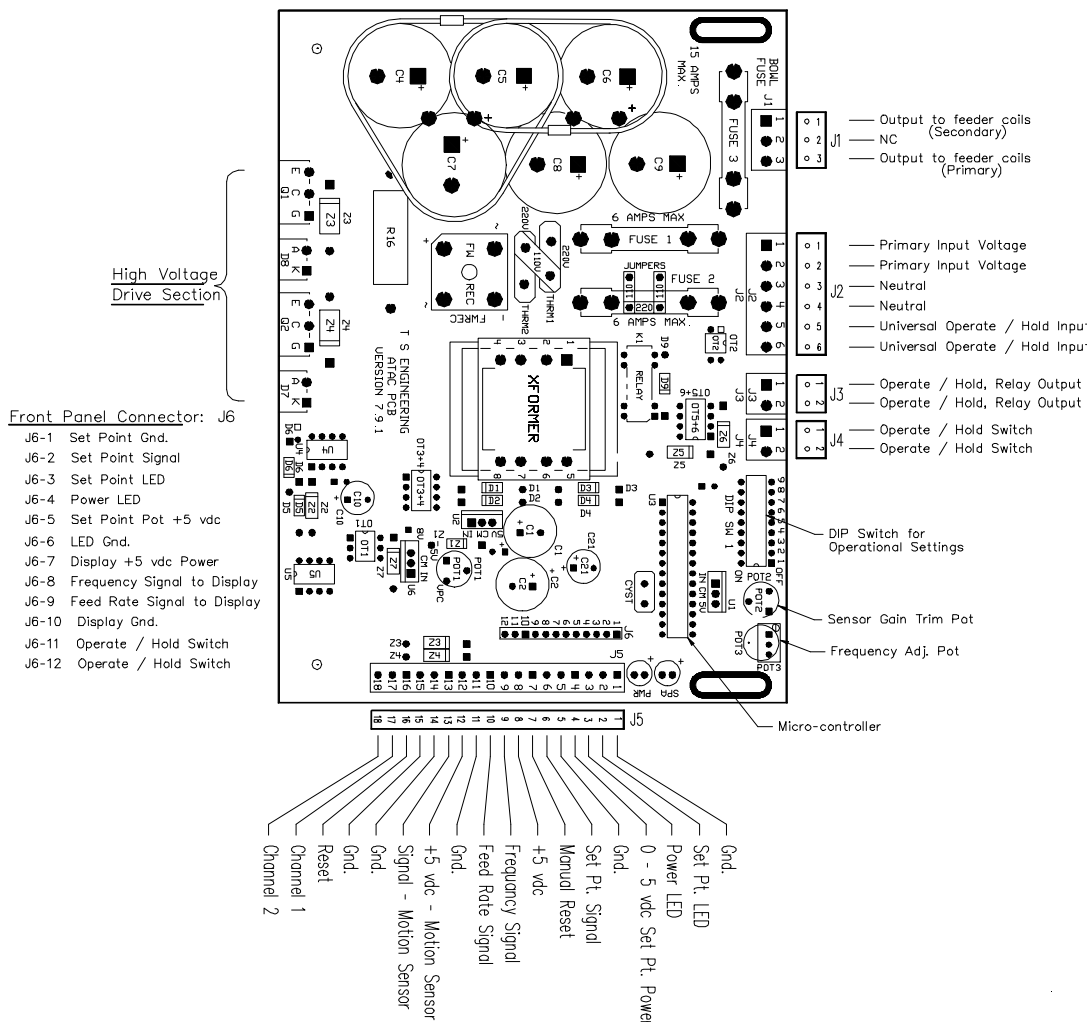

Figure 4. Diagram of the circuit board showing location of the fuses, DIP switches and trim-pots
Circuit Board Version 7.9.1

The ATAC Circuit Board 7.9.2

! TO INSURE OPERATOR SAFETY, INTERNAL ADJUSTMENTS AND/OR FUSE SERVICING SHOULD ALWAYS BE DONE WITH THE ATAC CONTROLLER TURNED OFF AND UNPLUGGED!

Located on the circuit board are three trimpots labeled **POT1**, **POT 2** and **POT3**, and two fuses for the 110 volt unit and three fuses for the 220 volt unit. **POT1** is factory preset and *should never be adjusted*. **POT2** and **POT3** are user-serviceable adjustments.

If fuse replacement is required, use only 0.25" × 1.25" size fuses. The following values apply.

- (110 Volt) **F1** – 7 Amps RMS Max, **F3** – 15 Amps RMS Max
- (220 Volt) **F1 & F2** – 4 Amps RMS Max, **F3** – 7 Amps RMS Max

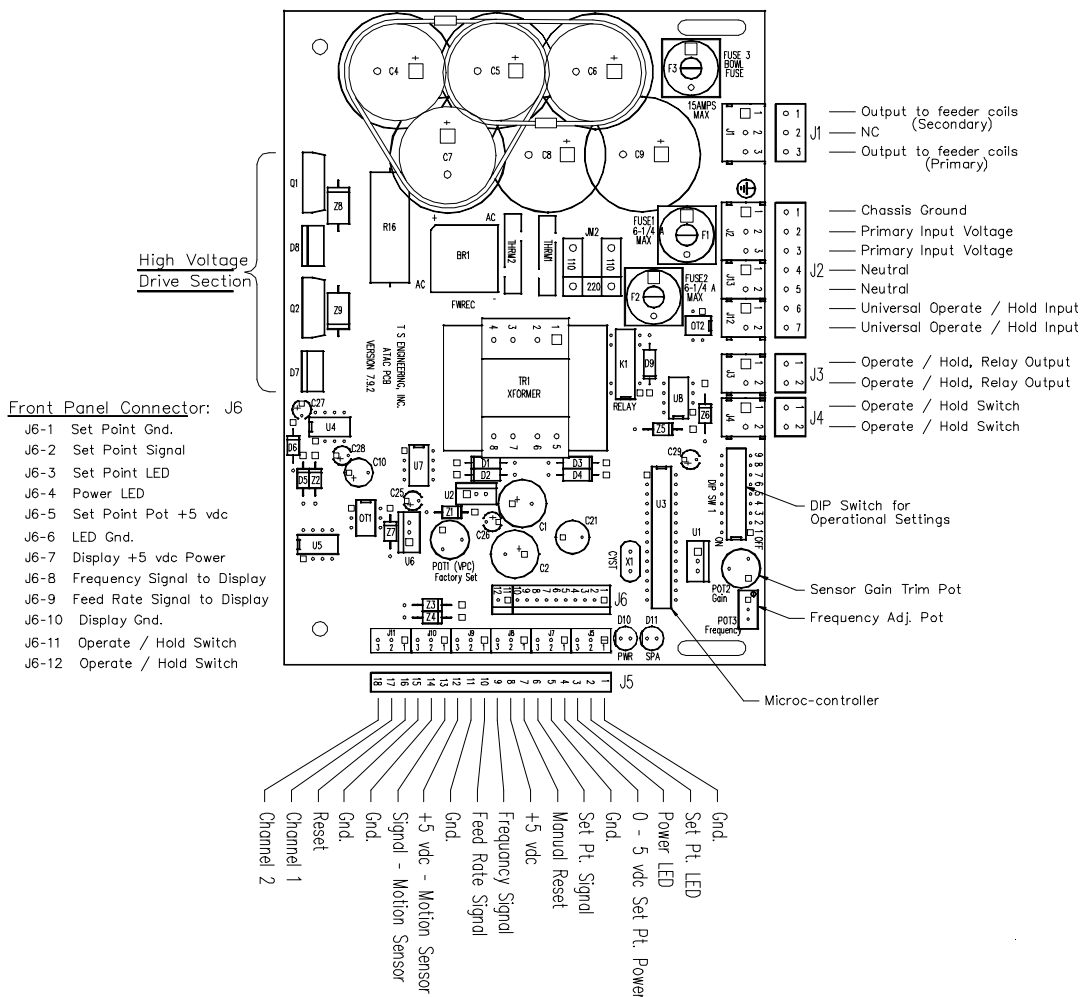

Figure 5. Diagram of the circuit board showing location of the fuses, DIP switches and trim-pots
Circuit Board Version 7.9.2 CE Approved

DIP Switch Settings

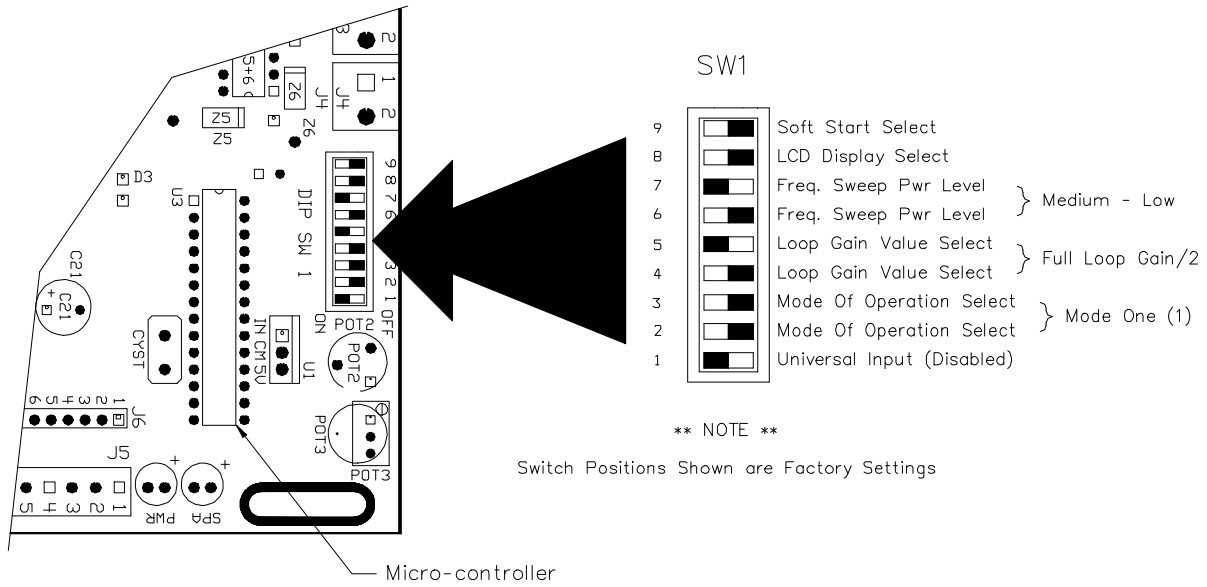

Figure 6: DIP Switch Location and Settings

DESCRIPTION OF DIP SWITCH SETTINGS:

- Switch (1) Universal Input (Disabled)
- Switch (2) Mode of Operation Select
- Switch (3) Mode of Operation Select
- Switch (4) Loop Gain Value Select
- Switch (5) Loop Gain Value Select
- Switch (6) Frequency Sweep Power Level Select, Mode One (1) Only
- Switch (7) Frequency Sweep Power Level Select, Mode One (1) Only
- Switch (8) LCD Display Select
- Switch (9) Soft Start Select

Modes Of Operation

There are four (4) *Modes of Operation*:

MODE 1: Frequency Sweep Active Tuning Amplitude Control. (*page 15*)

MODE 2: Fixed Frequency, Active Tuning Amplitude Control. (*page 15*)

MODE 3: Fixed Frequency Amplitude Control. (*page 17*)

MODE 4: Open Loop Control. (*page 18*)

MODE 1 *The Standard Mode Of Operation, is the Factory Preset Mode*

Switch 2 = Off

Frequency Sweep Active Tuning Amplitude Control:

Switch 3 = Off

In this mode the **ATAC** will perform a frequency sweep after power up. The sweep will begin at **160 Hz**, and will end at **40 Hz**. This sweep will last approximately 20 seconds. Upon completion of the frequency sweep the **ATAC** will go into "*normal operation*" at the drive frequency, which resulted in the highest amplitude of feeder motion. This amplitude becomes the Set Point for operating the feeder at its natural or resonant frequency.

During "*normal operation*" the **ATAC** will automatically adjust the output voltage to maintain the vibration intensity at the desired Set Point (*Amplitude Control*), and continuously adjust the output drive frequency to keep the feeder operation at resonance for maximum efficiency (*Active Tuning*).

NOTE: The Output Voltage Level used during the Frequency Sweep is determined by the settings of DIP switched 6 & 7. (Figure 6)

MODE 2 *The main purpose of MODE (2) is to avoid the 20 sec freq. sweep at power up*

Switch 2 = **On**

Fixed Frequency, Active Tuning Amplitude Control:

Switch 3 = Off

In this mode the **ATAC** will go into "*normal operation*" at the drive frequency selected during the frequency control adjustment. (*see page 16*) During operation the **ATAC** will automatically adjust the output voltage to maintain the vibration intensity at the desired set point (*Amplitude Control*) and continuously adjust the output drive frequency to keep the feeder operating at the selected drive frequency (*Active Tuning*).

FREQUENCY CONTROL ADJUSTMENT:

1. Set Switch **2 = On**
2. Set Switch **3 = On**
3. Set Switch **6 & 7** to desired *Frequency Range*

I. Select the desired position of switch 6 & 7:

- | | |
|---|---------------------|
| <p>A. Set Switch 6 = On</p> <p style="padding-left: 40px;">Set Switch 7 = On</p> | <p>40 - 70 Hz</p> |
| <p>B. Set Switch 6 = Off</p> <p style="padding-left: 40px;">Set Switch 7 = On</p> | <p>70 - 100 Hz</p> |
| <p>C. Set Switch 6 = On</p> <p style="padding-left: 40px;">Set Switch 7 = Off</p> | <p>100 - 130 Hz</p> |
| <p>D. Set Switch 6 = Off</p> <p style="padding-left: 40px;">Set Switch 7 = Off</p> | <p>130 - 160 Hz</p> |

II. Locate POT3 at the lower right corner of main circuit board:

POT3 adjusts the frequency in 1/8 Hz increments. Adjust **POT3** (*Figure 7*) to sweep within the selected frequency range, until the correct startup (*drive*) frequency is found. The frequency will be displayed on the LCD display continuously until the setup procedure is completed.

III. Once the desired startup (drive) frequency has been established on the LCD display:

- A. Set Switch **3 = Off**

IV. The unit is now set in mode 2:

NOTE: The adjustable value set above is read only once, at **POWER UP**.

NOTE: The primary purpose of this mode is to avoid the 20-second frequency sweep at power up. Eliminating this frequency sweep feature results in the startup (*drive*) frequency "**NOT**" being automatically found. The drive frequency set during the above frequency control adjustment will be the startup (*drive*) frequency.

MODE 3 *In this mode of operation there is no frequency sweep and the frequency is fixed (no active tuning)*

Switch 2 = Off

Fixed Frequency Amplitude Control:

Switch 3 = On

In this mode the ATAC will go into "*normal operation*" at the drive frequency selected during the frequency control adjustment. (*see below*) During operation (*Amplitude Control*) is performed but there is no adjustment made to the drive frequency (*Active Tuning* is turned off).

FREQUENCY CONTROL ADJUSTMENT:

1. Set Switch 2 = On
2. Set Switch 3 = On
3. Set Switch 6 & 7 to desired *Frequency Range*

I. Select the desired position of switch 6 & 7:

- | | |
|-----------------------|--------------|
| A. Set Switch 6 = On | 40 - 70 Hz |
| Set Switch 7 = On | |
| B. Set Switch 6 = Off | 70 - 100 Hz |
| Set Switch 7 = On | |
| C. Set Switch 6 = On | 100 - 130 Hz |
| Set Switch 7 = Off | |
| D. Set Switch 6 = Off | 130 - 160 Hz |
| Set Switch 7 = Off | |

II. Locate POT3 at the lower right corner of main circuit board:

POT3 adjusts the frequency in 1/8 Hz increments. Adjust POT3 (*Figure 7*) to sweep within the selected frequency range, until the correct startup (*drive*) frequency is found. The frequency will be displayed on the LCD Display continuously until the setup procedure is completed.

III. Once the desired startup (drive) frequency has been established on the LCD display:

- A. Set Switch 2 = Off

IV. The unit is now set in mode 3:

NOTE: The adjustable value set above is read only once, at **POWER UP**.

MODE 4 (*Obsolete 10-1-05*) Revised 10-16-05

Operating the ATAC

This section describes some of the advanced features available with the **ATAC**, as well as suggested adjustments to enhance feeder performance.

Frequency Sweep Power Level

This adjustment only applies when the **ATAC** is setup to run in **Mode 1**. The initial *frequency sweep* is performed so that the controller can find the natural *resonant frequency* of the feeder. However, as the sweep passes through the resonant frequency the feeder may vibrate excessively. In this event you will want to decrease the frequency sweep power level. On the other hand, if the feeder is heavily loaded upon power up then the vibration intensity at the natural frequency may be too small, and the controller may not accurately detect resonance. In this event, you will want to increase the frequency sweep power level. It may be necessary to adjust the frequency sweep power level to accommodate these two extremes, but the factory-preset value should work well on most feeders.

There are four frequency sweep power level settings

1. Low
2. Medium - Low
3. Medium - High
4. High

The sweep level is selected via DIP switches 6 and 7 as follows:

Switch 6 = ON Switch 7 = ON	Low	} ONLY VALID IN MODE 1
Switch 6 = OFF Switch 7 = ON	Medium - Low (factory preset)	
Switch 6 = ON Switch 7 = OFF	Medium - High	
Switch 6 = OFF Switch 7 = OFF	High	

Full Scale Intensity Adjust

This adjustment is made with **POT2**. (*Figure 6*) The potentiometer alters the gain on the motion sensor, and thus changes the value of the full scale vibration intensity as set via the Vibration Intensity Setpoint knob on the front panel. Rotating this pot fully clockwise (**12 o'clock**) causes maximum motion sensor gain, and thus minimum full scale vibration intensity. Fully counter clockwise rotation (**6 o'clock**) causes minimum vibration sensor gain, and thus maximum full scale vibration intensity. There is a factor of 4 between fully CCW and fully CW rotation.

Loop Gain (see *Figure 6*)

This adjustment results in a tradeoff between speed of response (*to a step change of the set point, or sudden bowl loading*) and control stability. There are four loop gain values to choose from, and they are selected by **DIP Switches 4 and 5** as follows:

Switch 4 = **ON** Full Loop Gain. This results in the fastest response, but
 Switch 5 = **ON** may result in unstable amplitude control for some feeders.

Switch 4 = **OFF** Full Loop Gain / 2 (factory preset)
 Switch 5 = **ON**

Switch 4 = **ON** Full Loop Gain / 4
 Switch 5 = **OFF**

Switch 4 = **OFF** Full Loop Gain / 8 Most stable, but is the slowest.
 Switch 5 = **OFF**

ONLY
 VALID
 IN
 MODES
 1, 2 and 3

A High Q (*gain*) bowl or feeder may be difficult to control with a large loop gain. In this case, select a lower loop gain.

Universal Input Enable for Operate / Hold (see *Figure 6*)

The Universal Input allows remote operation of the **Operate / Hold** feature. Any voltage, AC or DC, from 5 Volts RMS minimum to 120 Volts RMS maximum applied to **J2** pins **5** and **6** *Figure 4 (Version 7.9.1)* and **J2** pins **6** and **7** *Figure 5 (Version 7.9.2)* will put the unit in **OPERATE** mode. A zero Volt input applied to **J2** pins **5** and **6** *Figure 4 (Version 7.9.1)* and **J2** pins **6** and **7** *Figure 5 (Version 7.9.2)* will put the unit into **HOLD** mode. The contact closure input (**J4**) will still function normally.

The input impedance of the Universal Input is very high to allow connection to a photocell.

✘ **CONNECTING ANY VOLTAGE ACROSS THE CONTACT CLOSURE OPERATE / HOLD INPUTS (J4-1 AND J4-2) MAY DAMAGE THE CIRCUIT AND VOID YOUR WARRANTY!**

Switch 1 = **ON** Universal Input disabled (factory preset)

Switch 1 = **OFF** Universal Input enabled.

Operate / Hold Relay Output

This feature is useful for communicating the operational status of the unit to either another **ATAC**, a PLC, or any other monitoring device. For maximum flexibility the output is across relay contacts controlled by the onboard computer, and supplies no signal of its own. Connector **J3** provides access to the contacts, and they are rated to switch between 0 and 250 Volts RMS, AC or DC, with a maximum load of 1 Amp.

Status = **OPERATE** Relay Contacts closed.
 Status = **HOLD** Relay Contacts open.

Display Select

Only valid for models with the LCD display. This switch selects between displaying frequency or speed. It is redundant to the front panel switch in AT-x050 models, and should be left in the off position for them. For OEM kit versions with LCD Displays, this switch eliminates the need for a panel switch to select frequency or speed. In this configuration, the display signal wire should be connected to position 3 of J4.

Switch 8 = **ON** Frequency Display override
 Switch 8= **OFF** **Speed Display – Frequency selectable via panel switch (factory preset)**

Soft Start

Many vibratory feeders will “surge” on restart (when going from Hold to Operate). This will not happen if the feeder is excited at its natural frequency, as in Modes 1 & 2, but may occur in Mode 3 where the feeder may be run at a frequency different from resonance. The Soft Start feature eliminates this surging by slowly ramping the power up to the specified set point over a period of one second.

Switch 9 = **ON** Soft Start enabled
 Switch 9= **OFF** **Soft Start disabled (factory preset)**

Master / Slave Interconnection

If it is desirable to have two separate drive outputs with the same voltage and frequency that are triggered at identical intervals (such as when running very large feeders with multiple coils), the ATAC provides a useful feature that permits two different units to share a common control base.

- ✘ THIS FEATURE IS LIMITED IN SCOPE TO INTERCONENCTING TWO ATACS, AND DAISY CHAINING MORE THAN TWO SHOULD NEVER BE ATTEMPTED! ANY DAMAGE WHICH ARISES FROM ATTEMPTING TO MASTER / SLAVE MORE THAN TWO UNITS WILL NOT BE COVERED UNDER WARRANTY!**

Access to **Master / Slave** operation is accomplished through connector **J5**, pins 15 through 18 (see Figure 4, page 11 and Figure 5 page 12). These pins tie directly to the TTL signal path, so care should be used when performing the following procedure.

1. On the **ATAC** designated to be the Slave, turn off and unplug the unit. Then, at a ESD-safe work station open the enclosure and carefully remove the socketed CPU (U3) with a suitable tool, taking care not to touch or damage the pins of the IC.
2. Interconnect the two **ATAC** units by wiring connector locations **J5-15** through **J5-18** one-for-one (i.e. **J5-15** of the Master to **J5-15** of the Slave, etc.) Failure to match connector locations exactly could result in improper operation of one or both units.

- ✘ CONNECTING ANY SOURCE ACROSS J5-15 THROUGH J5-18 OTHER THAN THE TTL-LEVEL CONTROL SIGNAL FROM AN ATAC COULD RESULT IN DAMAGE TO THE HIGH-VOLTAGE DRIVE SECTION AND WILL VOID YOUR WARRANTY!**

Since this is a low voltage, high frequency digital signal, shielded wire is highly recommended for proper operation. Ideally, a 4-conductor, twisted-pair shielded cable should be used even for very short connections, and is *required* for distances greater than two feet between the Master and Slave units.

3. When powering up the Master / Slave combo, **ALWAYS** turn the Master unit **ON last** and **OFF first**. This is necessary because only the Master unit senses feeder motion and adjusts output voltage accordingly to maintain consistent performance. Turning the Slave unit on or off while the Master is operating will effectively double or halve the output (respectively) to the feeder motor, and may cause momentary surging in the Master's output before it is able to compensate. The length of time this surging requires to correct is a direct function of the loop gain, and low settings of gain may allow possible overdriving of the feeder coils or the **ATAC** for several seconds.

Once this procedure is complete, all functions of the Slave will be controlled only by the Master. It is important to note that in this configuration all controls and signals other than the Power switch and Feeder Bowl Power Outlet will be rendered null on the Slave unit. The frequency, voltage and operational status adjustments and indicators will function normally on the Master, but they will affect both units identically, and the Slave's output will always mirror the Master's.

Wiring Diagrams

Motion Sensor DIN Connector Wiring Diagram:

Pin-out on DIN to J5 on Main Board

1 +	12
2 -	14
3 NC	NC
4 NC	NC
5 Signal	13
Shell	Shield

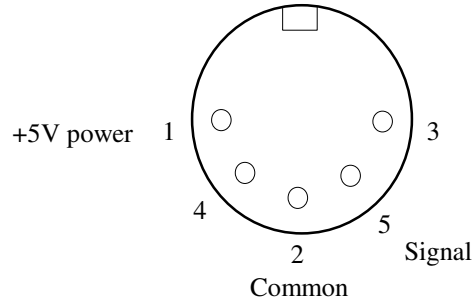

Contact Pins: Viewed from back side of DIN connector

Motion Sensor SR30 CE Connector Wiring Diagram:

Pin-out on SR30 to J5 on Main Board

1 +	12
2 -	14
3 Signal	13
4 NC	NC

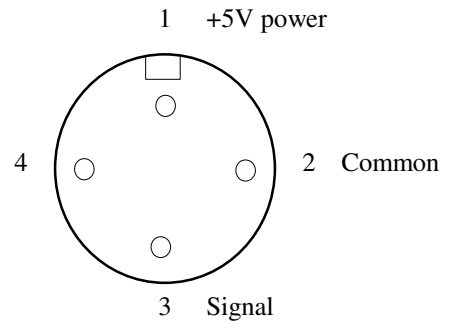

Contact Pins: Viewed from mating side

LCD Display (Optional) Wiring Diagram

For a single display to display both speed and frequency (switched):

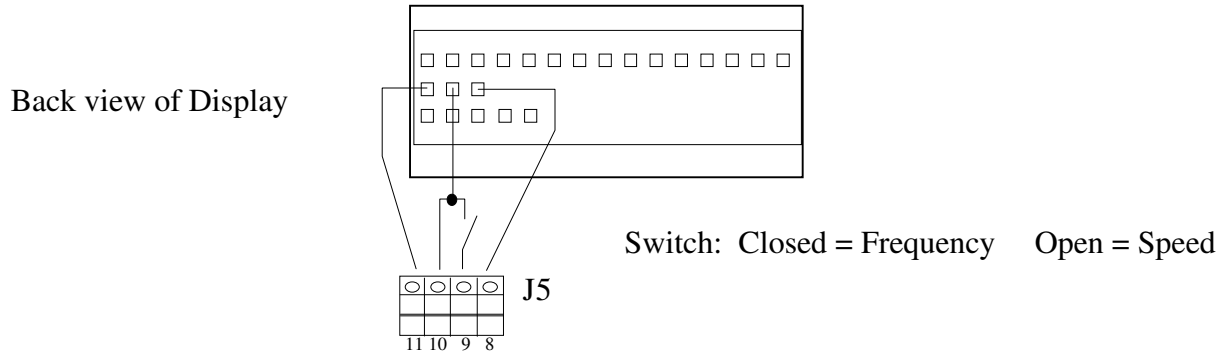

For two separate displays, one each for speed and frequency:

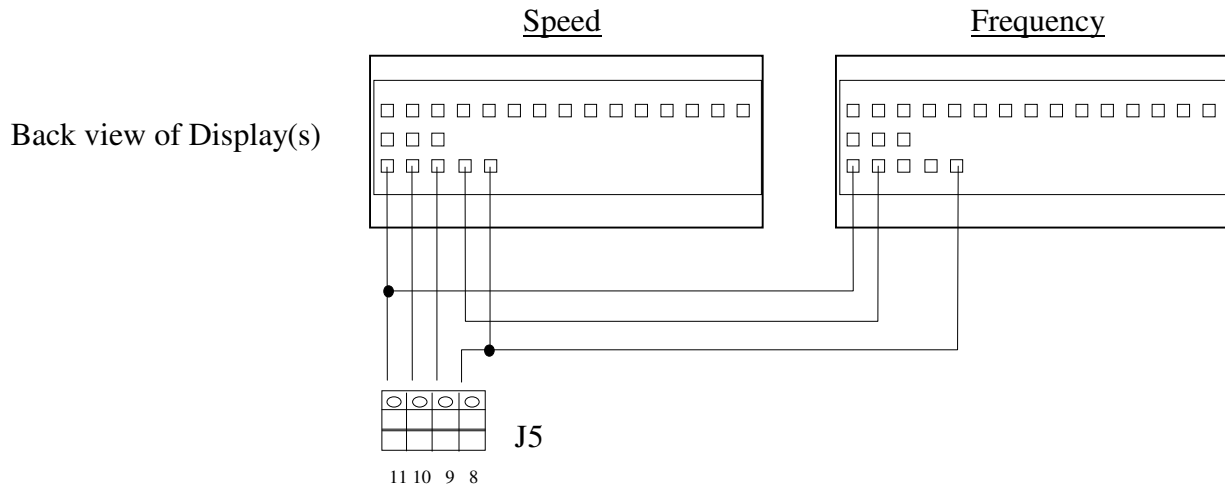

	110 Volt ATAC		220 Volt ATAC	
	Input	Output	Input	Output
Voltage	95-140 VAC	0-125 VAC	190-250 VAC	0-250 VAC
Current	7 Amps RMS	15 Amps RMS	4 Amps RMS ¹	7 Amps RMS ²
Frequency	45-65 Hz	40-160 Hz	45-65 Hz	40-160 Hz

Maximum continuous output is derated 1 Amp for each 3° ambient rise above 40° Celsius (104° F)

Recommended Replacement Fuse Values

110 Volt ATAC		220 Volt ATAC	
Input	Output	Input	Output
250V, 7 Amp Slow-Blow	250V, 15 Amp Fast-Acting Ceramic Type	250V, 4 Amp Slow-Blow	250V, 7 Amp Fast-Acting Ceramic Type

These are maximum values. Do *NOT* use a fuse with a value higher than that recommended for your particular model.

Smaller output fuse values may be used to prevent accidental overdriving of equipment.